



# Thermolizer

# TZ6 & TZ17

## Operators' Manual

Belshaw Bros., Inc.

814 44<sup>th</sup> Street NW, Suite 103

Auburn, WA 98001 USA

Phone: 206-322-5474 • Fax: 206-322-5425

Email: [service@belshaw.com](mailto:service@belshaw.com) • <http://www.belshaw.com>



Congratulations on buying a new Thermolizer from Belshaw Bros., Inc. Please inspect the unit carefully for damage or missing pieces immediately after receiving your system. Belshaw cannot pay for shipping damage, because the freight company has accepted the machine from Belshaw in good condition, and is responsible for its safe delivery. For your protection, each crate should be inspected before signing the Bill of Lading to report any visible damage caused by the trucker in transit, and account for the number of crates.

**IMPORTANT**  
**Keep this manual for future reference.**

**EQUIPMENT RECORD**

Please provide the information below when you correspond with us about your machine.

Purchased by \_\_\_\_\_

Installed by \_\_\_\_\_

Date of Installation \_\_\_\_\_

Model number \_\_\_\_\_

Serial number \_\_\_\_\_

120308  
MN-1257EN  
Belshaw Bros., Inc.  
814 44<sup>th</sup> Street NW, Suite 103  
Auburn, WA 98001 USA  
Phone: 206-322-5474 • Fax: 206-322-5425  
Email: [service@belshaw.com](mailto:service@belshaw.com) • <http://www.belshaw.com>



# Contents

<b>1</b>	<b>Operation</b>	<b>1</b>
	Control Functions	1
	Operation Instructions	1
<b>2</b>	<b>Cleaning</b>	<b>3</b>
	Water Box	3
	Thermolizer	3
	Water Filtration System	3

# Preface

The Thermolizer is designed for retail bakeries, in-store bakeries and donut shops. It features two individual insulating clear acrylic doors with stainless steel tops, bottoms and ends, to enable loading and unloading of 3 screens or bun pans per door. This minimizes heat and humidity loss. The air is recycled every 18 seconds.

A thorough understanding of how to operate, clean, and maintain the Thermolizer safely will prevent production delays and injuries. The operator must work safely at all times, read and follow the instructions in this manual, and heed all warnings, including the following:

- To avoid electrocution or other injury, turn off the machine's main power before attempting any cleaning, disassembly, adjustment, or repair.
- To avoid damaging the machine, never use force to assemble, disassemble, operate, clean, or maintain it.
- Be careful never to get water or other materials on the floor. If anything does get spilled on the floor, mop it up immediately. Materials on the floor can

cause people to slip or fall, resulting in serious injury or loss of life.

- To prevent unintentional startup and possible fire, disconnect the machine from the power source if there is a local power outage. When the power is restored, it is safe to connect the machine to the power source again.
- To avoid electrocution, make sure that all electrical cords are not frayed or cracked and that they do not pass through any water.
- Make sure that all electrical cords are routed so that no one will trip over them.
- If water is spilled while cleaning the proofer, be sure to dry the floor thoroughly.
- The autofill unit must be turned on to insure water is contained in the water box. Check often. Use only soft or distilled water in the operation of this thermolizer.

## Control Functions

- A. **HUMIDITY CONTROL:** This control is located inside the control box front panel and can only be adjusted by a qualified technician. It controls the water heating element. Set on high, the water heat element will remain on constantly. Set on any setting other than high, the control will cycle on and off. Higher numbered settings create a longer on-cycle and high humidity. The factory setting is 4.5 on the dial.
- B. **HEAT CONTROL:** This control is located inside the control box front panel and can only be adjusted by a qualified technician. It controls the air-heating element. The factory setting is: place the dot on the knob at 11:00 to produce 95 - 110F.
- C. **CONTROL BOX POWER SWITCH:** Controls the power to the control box.

### CAUTION

**Do not permit water pan to run out of water. Check often. Use only soft or distilled water in the operation of this proofer.**

## Operation Instructions

### CAUTION

**If water is spilled while filling the water pan, thoroughly dry all surfaces including the floor. Spilled water may cause serious injury, loss of life, or damage to equipment. Water may continue to drip. To prevent the floor from becoming wet and slippery, use a pan to collect dripping water. Do not move the proofer when water is in the reservoir.**

**Note: Use only distilled or purified water in the Thermolizer to avoid build-up in the water box of minerals and deposits normally found in tap water.**

1. Lift off water reservoir cover and fill water reservoir (see Figure 3). If necessary, open the lower door(s) and remove screen(s) or tray(s) to access the water reservoir. Do not fill beyond ½" of the top edge. When finished, replace the cover and doors. If equipped with the autofill unit, turn on the water and the filler unit will stop at the correct water level.

**Note: Do not pull the control box out to gain access to the water reservoir because water may be spilled when moving the control box.**

2. Turn on control box power switch.
3. Wait 25 minutes for the Thermolizer to reach operating temperature.

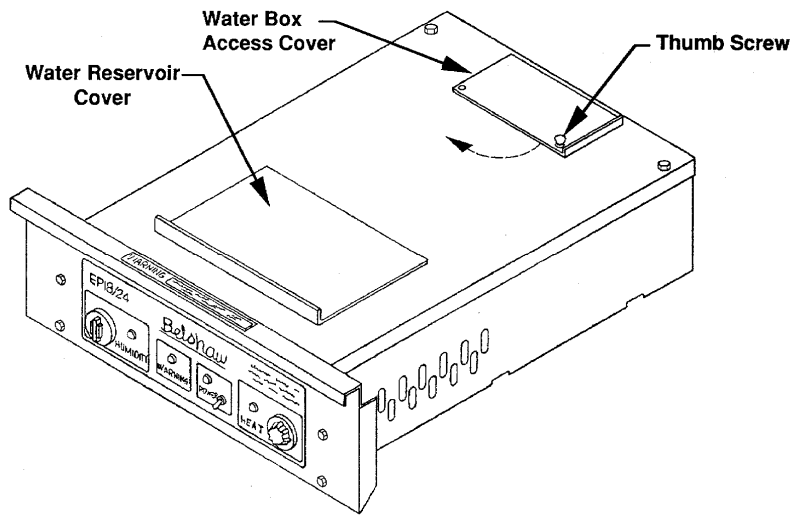

**FIGURE 3**



### **Water Box**

Once per day, clean the water box and reservoir as follows:

1. Remove the water reservoir cover.
2. Mix an appropriate cleaner into the water box and reservoir.
3. To break down lime scale, add 100-grain vinegar.
4. Brush the heating elements and float assembly to remove lime scale and sediment.
5. Remove water and cleaning solution.
6. Rinse thoroughly.

### **Thermolizer**

Once a week, clean the Thermolizer as follows:

1. Remove and clean Plexiglas doors with warm water.
2. Disconnect from power and remove control box from cabinet.
3. Remove and clean the screen rack angles, angle supports, and air duct.
4. Wipe the cabinet interior clean.
5. Special attention should be given to cleaning the water box (Item 2 of Control Box Assy.,

parts list drawings). Clean the water box as follows:

- a. Turn off water to the Thermolizer control box.
- b. Remove water reservoir cover.
- c. Empty the water reservoir pan.
- d. Remove water box access cover thumb screw and rotate access cover to open position. (see Figure 3)
- e. Use a rubber syringe baster to remove sediment from the water box. Wipe the inside of the water box with a rag.
- f. Add a small amount of water to the water reservoir pan. Water should flow freely into the water box. If not, clean out the water line between the water box and the water reservoir pan. Check for blockage at the water box inlet hole first.
- g. Close water box access cover and fasten with thumbscrew.
- h. Replace water reservoir cover.

### **Water Filtration System**

Clean any water filtration system per the manufacturer's instructions.

Following are some cleaning charts to help keep track of regularly scheduled cleaning.

<b>Cleaning Dates (Write In)</b>	<b>Drip Pans Cleaned (Check or Initial)</b>	<b>Proofer Box Cleaned (Check or Initial)</b>







# Thermolizer TZ6 & TZ17

## Technical Supplement

Belshaw Bros., Inc.

814 44<sup>th</sup> Street NW, Suite 103

Auburn, WA 98001 USA

Phone: 206-322-5474 • Fax: 206-322-5425

E-mail: [service@belshaw.com](mailto:service@belshaw.com) • <http://www.belshaw.com>



Congratulations on buying a new Thermolizer from Belshaw Bros., Inc. Please inspect the unit carefully for damage or missing pieces immediately after receiving your system. Belshaw cannot pay for shipping damage, because the freight company has accepted the machine from Belshaw in good condition, and is responsible for its safe delivery. For your protection, each crate should be inspected before signing the Bill of Lading to report any visible damage caused by the trucker in transit, and account for the number of crates.

**IMPORTANT**  
**Keep this manual for future reference.**

**EQUIPMENT RECORD**

Please provide the information below when you correspond with us about your machine.

Purchased by \_\_\_\_\_

Installed by \_\_\_\_\_

Date of Installation \_\_\_\_\_

Model number \_\_\_\_\_

Serial number \_\_\_\_\_

120308

MN-1258EN

Belshaw Bros., Inc.

814 44<sup>th</sup> Street NW, Suite 103

Auburn, WA 98001 USA

Phone: 206-322-5474 • Fax: 206-322-5425

Email: [service@belshaw.com](mailto:service@belshaw.com) • <http://www.belshaw.com>





# Contents

<b>1</b>	<b>Installation</b>	<b>1</b>
	Unpacking and Assembling the Thermolizer	1
<b>2</b>	<b>Maintenance</b>	<b>3</b>
<b>3</b>	<b>Troubleshooting</b>	<b>4</b>
<b>4</b>	<b>Appendix</b>	<b>7</b>

# Preface

The Thermolizer is designed for retail bakeries, in-store bakeries and donut shops. It features two individual insulating clear acrylic doors with stainless steel tops, bottoms and ends, to enable loading and unloading of 3 screens or bun pans per door. This minimizes heat and humidity loss. The air is recycled every 18 seconds.

A thorough understanding of how to operate, clean, and maintain the Thermolizer safely will prevent production delays and injuries. The operator must work safely at all times, read and follow the instructions in this manual, and heed all warnings, including the following:

- To avoid electrocution or other injury, turn off the machine's main power before attempting any cleaning, disassembly, adjustment, or repair.
- To avoid damaging the machine, never use force to assemble, disassemble, operate, clean, or maintain it.
- Be careful never to get water or other materials on the floor. If anything does get spilled on the floor, mop it up immediately. Materials on the floor can

cause people to slip or fall, resulting in serious injury or loss of life.

- To prevent unintentional startup and possible fire, disconnect the machine from the power source if there is a local power outage. When the power is restored, it is safe to connect the machine to the power source again.
- To avoid electrocution, make sure that all electrical cords are not frayed or cracked and that they do not pass through any water.
- Make sure that all electrical cords are routed so that no one will trip over them.
- If water is spilled while cleaning the proofer, be sure to dry the floor thoroughly.
- The autofill unit must be turned on to insure water is contained in the water box. Check often. Use only soft or distilled water in the operation of this thermolizer.

# 1

# Installation

## Unpacking and Assembling the Thermolizer

Use a forklift to transport the shipping crate to the workstation.

1. Break down the shipping crate.
2. Remove the packing materials from the thermolizer, including foam, tape, brown paper, plastic, and white protective coating. **Do not remove the plastic from the Plexiglas doors at this time.**
3. Cut the bands holding the control box in place and remove the control box from the cabinet.
4. Remove and discard the plywood that the control box was resting on.
5. Inspect the machine to see that no parts are bent, scratched, or otherwise damaged. If any damage has occurred in shipping, file a freight claim with the shipping company immediately.
6. Clean the humidifier water box and attach to filtered water per plumbing codes in your area. Refer to Section 3 for cleaning instructions.
7. Install screen rack angles onto angle supports by tilting the angles up and sliding the flange into the notches of the supports. See Figure 1.

### **WARNING**

**If water is spilled while cleaning the thermolizer, be sure to dry the floor thoroughly.**

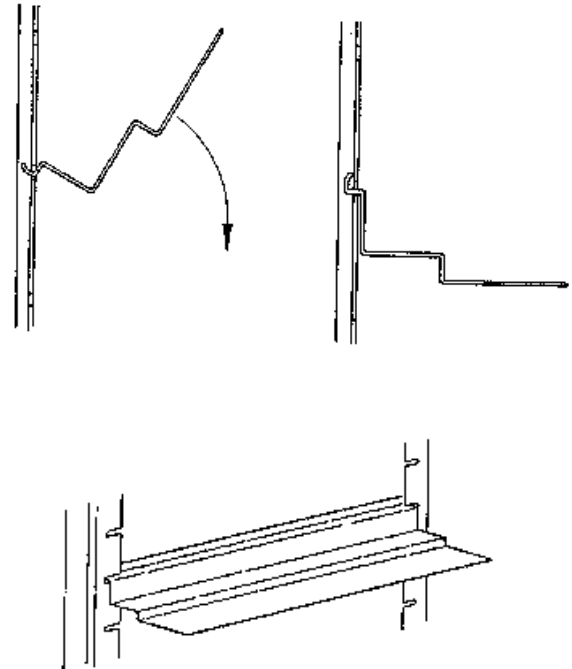

**Figure 1**

8. If not already done, remove the packing material from the control box and the put water reservoir cover in place over the water reservoir.
9. Place the control box into the cabinet, push the cord through the hole in the bottom to the right of the control panel, and close the cord opening cover plate.
10. Remove the protective covering from the Plexiglas doors. Clean the doors with warm water.
11. Insert the hinge pin on the right side of the door into place, and then slip the left side hinge pin into the slot.

---

**Note: due to vibration in shipping, the door handles might get out of adjustment. To adjust door handles: loosen the screws which fasten the handle to the Plexiglas door, adjust position of the handle so it just clears the bottom of the door above when both are closed, and tighten the screws. If more than one door handle requires adjustment, start with the one nearest the top of the proofer and work down.**

12. Turn the control box power switch to the off position (see Operation Instructions)
13. Connect Thermolizer cord to power source provided from the ThermoGlaze main power box. Mail the attached warranty registration form within ten days of installation.
14. Keep this manual for future reference. Put it where you know you can find it.

## **Control Box with Auto Water System**

Remove the control box top to install the auto water line. After installation, replace the top and seal it with silicon seal 909-0021.F.

## **Initial Cleaning**

Remove all the packing materials. Wipe the Thermolizer with a soft, damp cloth. Dry these areas completely.

### **WARNING**

**To avoid electrocution or other injury, turn off the machine's main power before attempting any cleaning, disassembly, adjustment, or repair.**

# 2

# Maintenance

The Thermolizer requires no maintenance, other than the daily/weekly cleaning.

# 3

# Troubleshooting

If you have problems with your Thermolizer, call your dealer or another qualified technician.

If your dealer cannot help you, please call Belshaw. To do so, first dial the appropriate international access code, then 1-206-322-5474 (United States). When you call, please specify the following:

- The model name of the machine.
- The serial number of the machine.
- The voltages, phase, and cycle of the machine.

## WARNING

**If you perform repairs yourself or have them performed by anyone other than a service technician authorized by Belshaw Bros., you do so at your own risk.**

## WARNING

**Disconnect the machine from the power source before disassembling, repairing, or wiring.**

<b>THE PROOF BOX WILL NOT HEAT UP</b>	
<b>Possible Causes</b>	<b>What To Do</b>
Control box power switch is not on.	Flip switch to on position.
Defective heat control.	Replace the heat control.
Loose wire or bad connection.	Repair the wire.
Defective heat element.	Replace the heat element.
Defective control box power switch.	Replace power switch.
<b>LACK OF HUMIDITY OR UNEVEN HUMIDITY</b>	
<b>Possible Causes</b>	<b>What To Do</b>
Low water.	Refill water reservoir/Check water is on.
Defective humidity control.	Replace the humidity control.
Defective water heat element.	Replace the water heat element.
Restriction or sediment in the water line or the water heat box inlet hole.	Clean out water line.
Loose wire or bad connection in humidity circuit.	Repair loose wire or connection in humidity circuit.
Blower is not running.	See “Blower Will Not Run” section
Doors out of alignment.	Align doors.

**BLOWER WILL NOT RUN**

<b>Possible Causes</b>	<b>What To Do</b>
Control box power switch is not on.	Flip switch to on position.
Defective blower motor.	Replace blower motor.
Defective control box power switch.	Replace control box power switch.
Loose wire or bad connection in blower control circuit.	Repair loose wire or bad connection.



See Parts List Drawing Insert Page.